



AGILENT ROTARY VANE PUMPS

2-3	Features and Benefits
4-5	Typical Applications
6-19	Pump Models
20	Accessories
21	HS Series Pumps Features and Benefits
22-25	HS Series Pump Models
26-27	MS 40+ Pump Features and Benefits
28-29	MS 40+ Pump Model



Agilent Technologies

AGILENT ROTARY VANE PUMPS FEATURES AND BENEFITS

A reliable line of pumps to cover the most demanding industrial and scientific applications

- Thanks to a very simple and highly reliable design, these field proven rotary vane pumps provide excellent vacuum performance. Agilent's quality and manufacturing standards ensure that the DS Rotary Vane Pumps provide high pumping stability for light gases, low noise, minimal oil backstreaming, and a long operating life.
- Agilent's DS Rotary Vane Pumps conform with CE and RoHS requirements, and all pumps are UL and CSA approved. Agilent's world class technical support organization makes the DS Rotary Vane Pump cost-effective and well suited for a wide range of applications.



Anti-suckback Valve and Vent Device

- This valve isolates the pump should it stop or be idle
- Prevents inadequate venting and oil contamination of the vacuum system when the pump is switched off, or in case of power fail



The new MS 40+ Mono Stage Rotary Vane Pump

- High capacity pumping speed with the smallest footprint
- Proven inverter technology
- Ideal for mass spectrometry and electron microscopy
- Lowest noise, highest throughput



HS Series "smart" pumps with green technology

- In 2004 Varian, now Agilent, introduced the first rotary vane pumps with truly "smart" capabilities
- Employ an innovative frequency inverter technology to deliver optimal and consistent performance
- Encompass the worldwide range of voltage and frequency conditions
- Environmentally friendly thanks to reduced power requirements and low start up current



Forced Oil Circulation

- The dedicated oil circulation gear pump ensures efficient and reliable lubrication of the pump from atmospheric pressure throughout the entire vacuum operating range



Built-in Oil Shield

- This feature minimizes the oil mist at the pump exhaust
- Drastically reduces the oil consumption over long periods of operation
- Reduction of air pollution limiting the impact on the environment

ROTARY VANE PUMPS



Dual Stage Pumps

DS Series: the two stage design allows:

- Low 10^{-3} mbar operation
- Low operating temperature
- Minimal backstreaming at low pressure
- Good pumping efficiency and gas ballast in the low 10^{-2} mbar region



Worldwide Motors

- Pump motors, available as 1-phase or 3-phase, are suitable for all voltages and frequencies worldwide
- Operational voltages are easily selectable, allowing greater flexibility, easy planning and inventory reduction



Socket Type IEC320

- Permits use of standard power cable
- Eliminates the need to open box and wire the motor

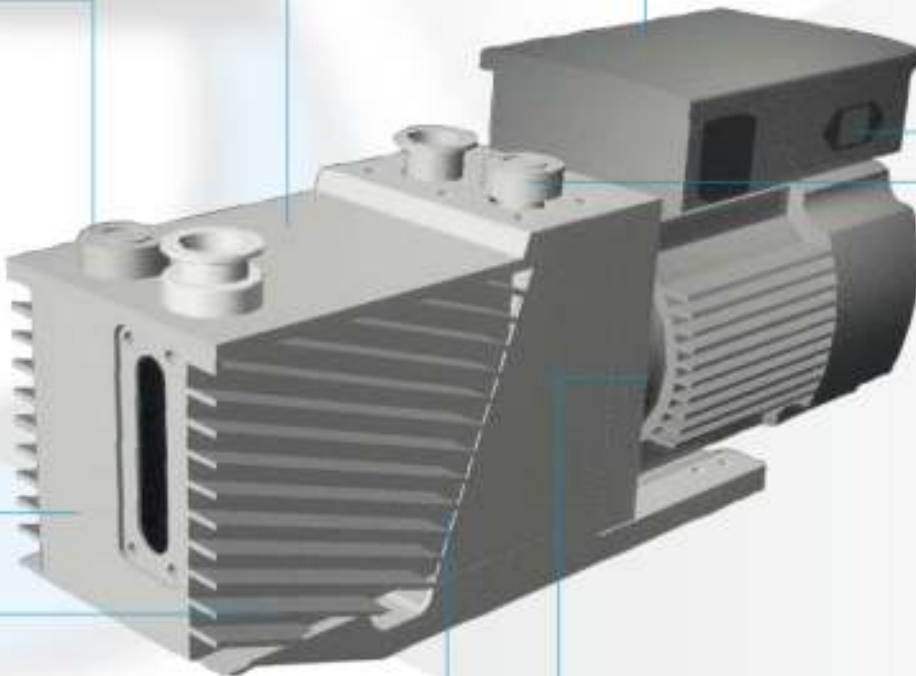

Gas Ballast Valve

- The opening of this valve injects dry air into the second stage of the pump
- This action increases the temperature of the module which facilitates the outgassing and clean up of water vapor or other condensable gases from the oil



Alignment Pins on Pump Module

- The pump module components are assembled and positioned by built-in alignment pins
- These speed up the assembling and maintenance process, avoiding any error



Forced Air Ventilation

The cooling fan between the motor and the pump:

- Reduces the pump operating temperature
- Lowers the oil vapor partial pressure
- Minimizes oil backstreaming and vacuum system contamination

Agilent TurboVane Pumps Typical Applications



ICP-MS. Photo courtesy Agilent Scientific Instruments.



Analytical Instruments and Mass Spectrometry

TurboVane Pumps are the most common primary vacuum pumps used in GC-MS, I C-MS, iCP-MS, and MAI di-ToF instruments.

GC-MS typically uses a small pump, the DS42; the pump is connected to the system and back to the high vacuum Turbo or Diffusion pump.

I C-MS and iCP-MS use a medium capacity pump at the sample injection/ system interface, typically a DS402 or a DS602, and a smaller pump to back the system Turbo pumps.

MAI di-ToF typically uses a system size, such as the DS102 to the DS602 as roughing or interface pumps.

Examples of high-throughput instruments, such as I C-MS and iCP-MS, can take advantage of the benefits of HS 452, HS 652 and MS 40+:

- Large pumping capacity
- Consistent worldwide performance thanks to universal voltage and frequency
- Single phase
- Low power requirements and start up current
- Remote control and diagnostic
- Adjustable performance, low noise
- Green technology

Electron Microscopes

Small pumps, typically the DS202 and the DS302, are typically used in conjunction with rough pumps to rough the system and the high vacuum Turbo or Diffusion pump, condensable vapor.

Leak Detection

Pumps in the DS102, DS202 and DS302 range are typically used to back the Helium Mass Spectrometer Turbo or Diffusion pump.

The roughing pump is usually bigger, typically up to the DS402/ DS602, and can still be installed on the Leak Detector itself, while bigger pumps can be used to pump down high throughput Leak Detection systems.

Rotary VANE Pumps

Rotary Vane Pumps



Freeze Drying equipment.



Distillation apparatus. Photo courtesy University of Torino, Italy.

Industrial Vacuum Processes

Vacuum chambers, Metalworking Vacuum Furnaces, lamps and TV Tube manufacturing, Sterilizers, Freeze dryers, glove Boxes, High Speed Centrifuges, and Flowhous (for microstruc) represent the main industrial applications for dry State Rotary Vane pumps. In the first few fields of application the Rotary Pumps are used as rough and back pumps for High Vacuum Turb or diffusion pumps, whereas in others the Rotary Pumps are the primary vacuum pumps of the system.

High Energy Physics and Research Laboratories

In these applications the Rotary Vane pumps are mainly used in combination with Turb pumps. The combination is typically used to rough and pump High Vacuum experimental chambers or to start up Pumps in ultra high vacuum systems.



LED-Lab. Photo courtesy PNNL

AGILENT ROTARY VANE PUMP MODELS

		DS 42	DS 102	DS 202
Free air displacement	60 Hz l/min (cfm)	45.5 (1.6)	114 (4)	192 (6.8)
	50 Hz l/min (m ³ /h)	38 (2.3)	95 (5.7)	160 (9.6)
Pumping speed*	60 Hz (cfm)	1.2	3.5	5.8
	50 Hz (m ³ /h)	1.8	5	8.3
Ultimate partial pressure* (mbar)		10 ⁻⁴	10 ⁻⁴	10 ⁻⁴
Ultimate total pressure* (mbar)		4 x 10 ⁻³	2 x 10 ⁻³	2 x 10 ⁻³
Ultimate total pressure with gas ballast* (mbar)		2 x 10 ⁻²	2 x 10 ⁻²	2 x 10 ⁻²
Water vapor tolerance (mbar)		15	15	15
Water vapor capacity (g/h)		25	60	100
Oil capacity min/max (l)		0.5 (max)	0.2/0.5	0.2/0.6
Motor rating 1 ph	60 Hz (kW)	0.2	0.45	0.45
	50 Hz (kW)	0.2	0.38	0.38
Motor rating 3 ph	60 Hz (kW)			
	50 Hz (kW)			
Nominal rotation speed	60 Hz (rpm)	3480	1800	1800
	50 Hz (rpm)	2280	1500	1500
Weight kg (lbs)		11 (24)	22 (48)	25 (55)
Inlet flange		16KF DN	25KF DN	25KF DN
Exhaust flange		16KF DN	25KF DN	25KF DN

*According to PNEUROP 6602



ROTARY VANE PUMPS

DS 302	DS 402	DS 602	HS 452	HS 652	MS 40+
285 (10) 237 (14.2)	410 (14.5) 342 (20.5)	605 (21.4) 504 (30.2)	456 (16.1) 456 (27.3)	672 (23.8) 672 (40.3)	828 (29.2) 828 (49.7)
8.2 11.6	12.3 17.4	17.6 25	13 22	19 32	23.5 40
10^{-4}	10^{-4}	10^{-4}	10^{-4}	10^{-4}	N/A
2×10^{-3}	2×10^{-3}	2×10^{-3}	2×10^{-3}	2×10^{-3}	5×10^{-2}
2×10^{-2}	1×10^{-2}	1×10^{-2}	1×10^{-2}	1×10^{-2}	N/A No gas ballast port
20	30	30	30	30	N/A No gas ballast port
160	350	550	350	550	N/A No gas ballast port
0.25/0.6	0.5/1	0.5/1	0.5/1	0.5/1	1
0.45 0.38	0.90 0.75	0.90 0.75			
	0.90 0.75	0.90 0.75	0.50	0.50	0.75
1800 1500	1800 1500	1800 1500	2000	2000	1450
25 (55)	35 (77)	35 (77)	33 (73)	33 (73)	33 (73)
25KF DN	25KF DN	25KF DN	25KF DN	25KF DN	25KF DN - 40KF DN
25KF DN	25KF DN	25KF DN	25KF DN	25KF DN	25KF DN



AGILENT ROTARY VANE PUMP MODELS

▶ Agilent DS 42

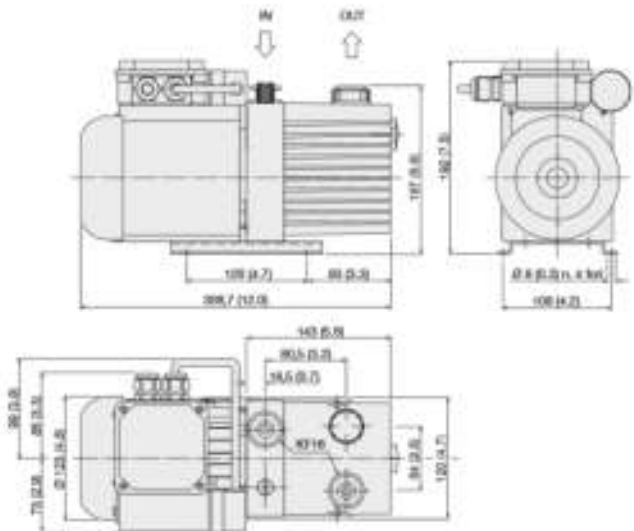

Dimensions: millimeters (inches)

Technical Specifications

Free air displacement	60 Hz: 45.5 l/min (1.6 cfm)	50 Hz: 38 l/min (2.3 m ³ /h)
Pumping speed*	60 Hz: 1.2 cfm	50 Hz: 1.8 m ³ /h
Ultimate partial pressure*		10 ⁻⁴ mbar
Ultimate total pressure*		4 x 10 ⁻³ mbar
Ultimate total pressure with gas ballast*		2 x 10 ⁻² mbar
Water vapor tolerance		15 mbar
Water vapor capacity		25 g/h
Oil capacity max		0.5 l
Motor rating 1ph	60 Hz: 0.2 kW	50 Hz: 0.2 kW
Nominal rotation speed	60 Hz: 3480 rpm	50 Hz: 2280 rpm
Weight		11 kg (24 lbs)
Inlet flange		16KF DN
Exhaust flange		16KF DN

* According to PNEURO P 6602

RoTARy VANE PumPs

DS 42 - Pump Speed Curve

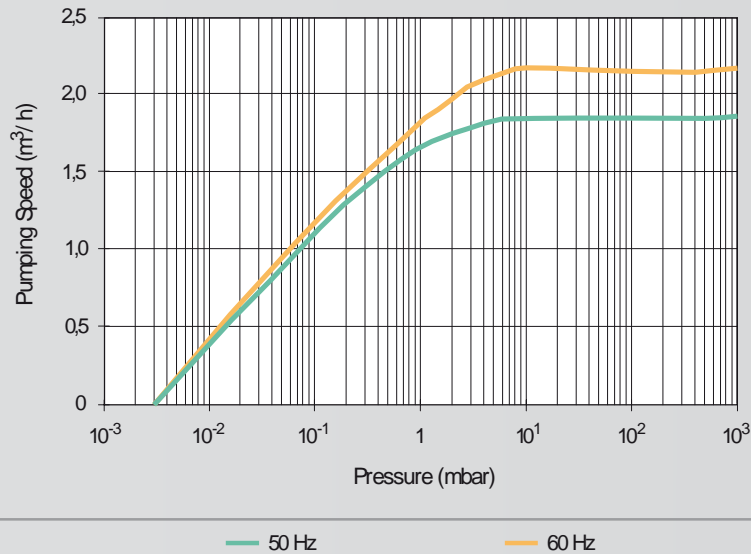

Rotary Vane Pumps

Ordering Information

Dual Stage Rotary Vane Pump	Part Number
DS 42 120V-60Hz	9499308
DS 42 220-240V - 50/ 60Hz	9499309

Oil and Accessories	Part Number
Rotary vane fluid, DS31 type, 0.5 liter	9499305
Oil mist eliminator KF16	9499388
Oil mist eliminator 3/ 4 G	9499387
DS 42 filter cartridge (pkg. of 2)	9499386
Oil drain extension	9499375
NW 16 centering ring Viton	KC16AV
NW 16 aluminum clamp	KQ16AWP

Power cable not available.

The correct cable for electrical wiring is a three wires (Ph+N+Earth) cable. The wire section has to be at least 1 mm² (AWG17), and the cable external diameter has to be between 7 mm to 12 mm.

AGILENT ROTARY VANE PUMP MODELS

▶ Agilent DS 102

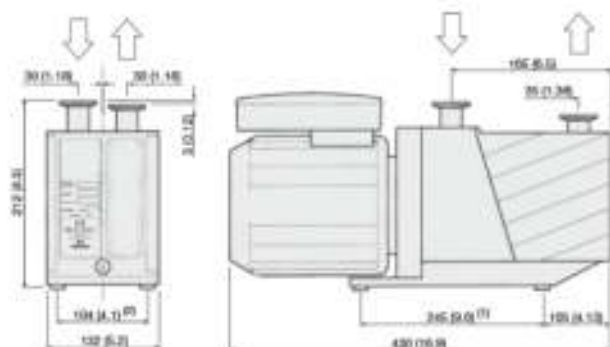

Alternative mounting holes are also available, with (1) = 226 (8.9) and (2) = 98 (3.8), with hole $\varnothing = 7$ (0.3)

Dimensions: millimeters (inches)

Technical Specifications

Free air displacement	60 Hz: 114 l/min (4 cfm)	50 Hz: 95 l/min (5.7 m ³ /h)
Pumping speed*	60 Hz: 3.5 cfm	50 Hz: 5 m ³ /h
Ultimate partial pressure*		10 ⁻⁴ mbar
Ultimate total pressure*		2 x 10 ⁻³ mbar
Ultimate total pressure with gas ballast*		2 x 10 ⁻² mbar
Water vapor tolerance		15 mbar
Water vapor capacity		60 g/h
Oil capacity min/max		0.2/0.5 l
Motor rating 1ph	60 Hz: 0.55 kW	50 Hz: 0.45 kW
Nominal rotation speed	60 Hz: 1800 rpm	50 Hz: 1500 rpm
Weight		22 kg (48 lbs)
Inlet flange		25KF DN
Exhaust flange		25KF DN

* According to PNEURO P 6602

DS 102 - Pump Speed Curve

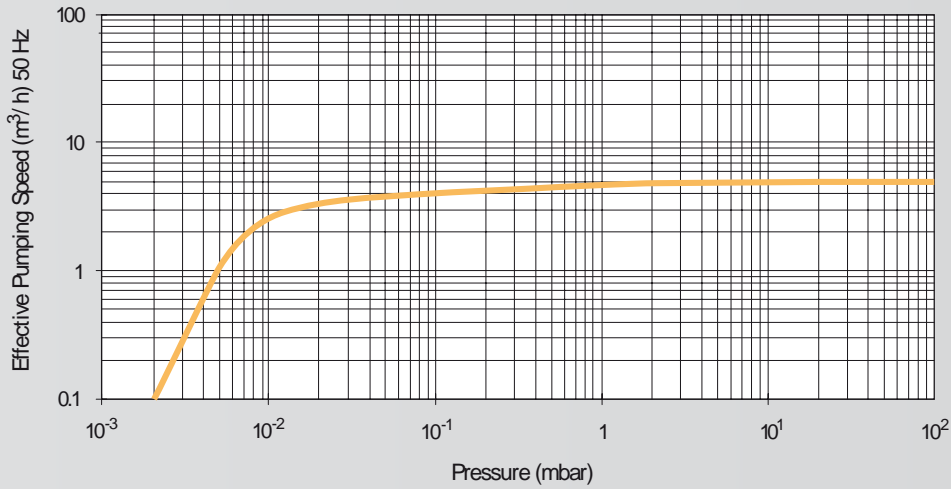

Ordering Information

Dual Stage Rotary Vane Pump	Part Number
DS 102 with 1 phase worldwide motor*	9499315
* 1 phase motors (100-120 / 200-230) V ±10%, 50/ 60 Hz All motors comply with CE and UL/ CSA standards.	
Minor Maintenance Kit	Part Number
Contains all the valves, O-rings and seals to refurbish the pump to vacuum integrity	9499370
Major Maintenance Kit	Part Number
Includes all the items of the minor kit plus the vanes	9499380

Oil and Accessories	Part Number
Rotary vane fluid, DS19 type, 1 liter	9499390
Rotary vane fluid, DS19 type, 1 liter (USA)*	K7516301
Rotary vane fluid, DS19 type, 1 gallon (USA)	K7516302
Oil mist eliminator	9499395
Oil mist replacement cartridge (pkg. of 2)	9499394
NW 25 oil exhaust filter	9499392
NW 25 oil exhaust replacement cartridge	9499342
Oil return kit	9499376
Oil drain extension	9499375
European plug power cable 2 meters 1 ph	9499396
USA plug power cable 2 meters 1 ph	9499397
UK plug power cable 2 meters 1 ph	9499398
NW 25 centering ring Viton	KC25AV
NW 25 aluminum clamp	KQ25AWP

* When these pumps are used in Leak Detectors applications, we recommend the use of Rotary Vane Fluid (Elite-Z mechanical), P/ N 695409005 as it features a lower vapor pressure.

AGILENT ROTARY VANE PUMP MODELS

▶ Agilent DS 202

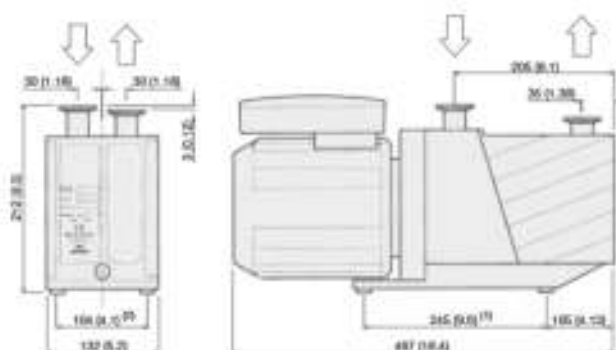

Alternative mounting holes are also available, with (1) = 226 (8.9) and (2) = 98 (3.8), with hole $\varnothing = 7$ (0.3)

Dimensions: millimeters (inches)

Technical Specifications

Free air displacement	60 Hz: 192 l/min (6.8 cfm)	50 Hz: 160 l/min (5.6 m ³ /h)
Pumping speed*	60 Hz: 5.8 cfm	50 Hz: 8.3 m ³ /h
Ultimate partial pressure*		10 ⁻⁴ mbar
Ultimate total pressure*		2 x 10 ⁻³ mbar
Ultimate total pressure with gas ballast*		2 x 10 ⁻² mbar
Water vapor tolerance		15 mbar
Water vapor capacity		100 g/h
Oil capacity min/max		0.25/0.6 l
Motor rating 1ph	60 Hz: 0.55 kW	50 Hz: 0.45 kW
Nominal rotation speed	60 Hz: 1800 rpm	50 Hz: 1500 rpm
Weight		25 kg (55 lbs)
Inlet flange		25KF DN
Exhaust flange		25KF DN

* According to PNEURO P 6602

RoTARy VANE PumPs

DS 202 - Pump Speed Curve

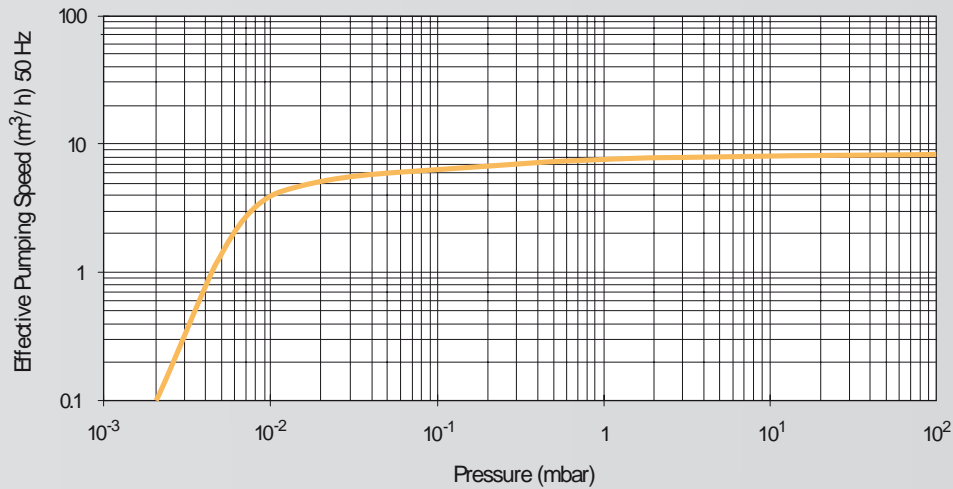

Rotary Vane Pumps

Ordering Information

Dual Stage Rotary Vane Pump	Part Number
DS 202 with 1 phase worldwide motor*	9499320
* 1 phase motors (100-120 / 200-230) V ±10%, 50/ 60 Hz All motors comply with CE and UL/ CSA standards.	
Minor Maintenance Kit	Part Number
Contains all the valves, O-rings and seals to refurbish the pump to vacuum integrity	9499370
Major Maintenance Kit	Part Number
Includes all the items of the minor kit plus the vanes	9499381

Oil and Accessories	Part Number
Rotary vane fluid, DS19 type, 1 liter	9499390
Rotary vane fluid, DS19 type, 1 liter (USA)*	K7516301
Rotary vane fluid, DS19 type, 1 gallon (USA)	K7516302
Oil mist eliminator	9499395
Oil mist replacement cartridge (pkg. of 2)	9499394
NW 25 oil exhaust filter	9499392
NW 25 oil exhaust replacement cartridge	9499342
Oil return kit	9499376
Oil drain extension	9499375
European plug power cable 2 meters 1 ph	9499396
USA plug power cable 2 meters 1 ph	9499397
UK plug power cable 2 meters 1 ph	9499398
NW 25 centering ring Viton	KC25AV
NW 25 aluminum clamp	KQ25AWP

* When these pumps are used in Leak Detectors applications, we recommend the use of Rotary Vane Fluid (Elite-Z mechanical), P/ N 695409005 as it features a lower vapor pressure.

AGILENT ROTARY VANE PUMP MODELS

▶ Agilent DS 302

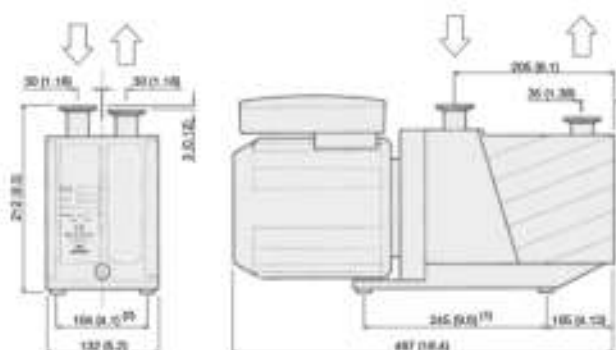

Alternative mounting holes are also available, with (1) = 226 (8.9) and (2) = 98 (3.8), with hole $\varnothing = 7$ (0.3)

Dimensions: millimeters (inches)

Technical Specifications

Free air displacement	60 Hz: 285 l/min (10 cfm)	50 Hz: 237 l/min (14.2 m ³ /h)
Pumping speed*	60 Hz: 8.2 cfm	50 Hz: 11.6 m ³ /h
Ultimate partial pressure*		10 ⁻⁴ mbar
Ultimate total pressure*		2 x 10 ⁻³ mbar
Ultimate total pressure with gas ballast*		2 x 10 ⁻² mbar
Water vapor tolerance		20 mbar
Water vapor capacity		160 g/h
Oil capacity min/max		0.25/0.6 l
Motor rating 1ph	60 Hz: 0.55 kW	50 Hz: 0.45 kW
Nominal rotation speed	60 Hz: 1800 rpm	50 Hz: 1500 rpm
Weight		25 kg (55 lbs)
Inlet flange		25KF DN
Exhaust flange		25KF DN

* According to PNEURO P 6602

RoTARy VANE PumPs

DS 302 - Pump Speed Curve

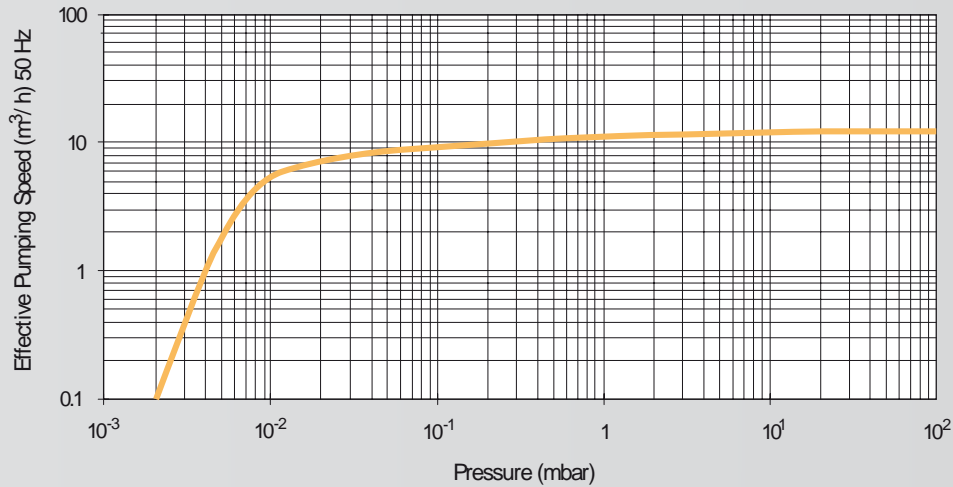

Rotary Vane Pumps

Ordering Information

Dual Stage Rotary Vane Pump	Part Number
DS 302 with 1 phase worldwide motor*	9499325
* 1 phase motors (100-120 / 200-230) V ±10%, 50/ 60 Hz All motors comply with CE and UL/ CSA standards.	
Minor Maintenance Kit	Part Number
Contains all the valves, O-rings and seals to refurbish the pump to vacuum integrity	9499370
Major Maintenance Kit	Part Number
Includes all the items of the minor kit plus the vanes	9499381

Oil and Accessories	Part Number
Rotary vane fluid, DS19 type, 1 liter	9499390
Rotary vane fluid, DS19 type, 1 liter (USA)*	K7516301
Rotary vane fluid, DS19 type, 1 gallon (USA)	K7516302
Oil mist eliminator	9499395
Oil mist replacement cartridge (pkg. of 2)	9499394
NW 25 oil exhaust filter	9499392
NW 25 oil exhaust replacement cartridge	9499342
Oil return kit	9499376
Oil drain extension	9499375
European plug power cable 2 meters 1 ph	9499396
USA plug power cable 2 meters 1 ph	9499397
UK plug power cable 2 meters 1 ph	9499398
NW 25 centering ring Viton	KC25AV
NW 25 aluminum clamp	KQ25AWP

* When these pumps are used in Leak Detectors applications, we recommend the use of Rotary Vane Fluid (Elite-Z mechanical), P/ N 695409005 as it features a lower vapor pressure.

AGILENT ROTARY VANE PUMP MODELS

▶ Agilent DS 402

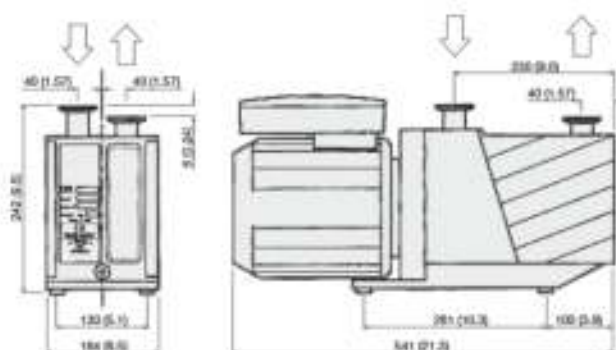

Technical Specifications

Free air displacement	60 Hz: 410 l/min (14.5 cfm)	50 Hz: 342 l/min (20.5 m ³ /h)
Pumping speed*	60 Hz: 12.3 cfm	50 Hz: 17.4 m ³ /h
Ultimate partial pressure*		10 ⁻⁴ mbar
Ultimate total pressure*		2 x 10 ⁻³ mbar
Ultimate total pressure with gas ballast*		1 x 10 ⁻² mbar
Water vapor tolerance		30 mbar
Water vapor capacity		350 g/h
Oil capacity min/max		0.5/1 l
Motor rating 1ph	60 Hz: 0.55 kW	50 Hz: 0.75 kW
Motor rating 3ph	60 Hz: 0.90 kW	50 Hz: 0.75 kW
Nominal rotation speed	60 Hz: 1800 rpm	50 Hz: 1500 rpm
Weight		35 kg (77 lbs)
Inlet flange		25KF DN
Exhaust flange		25KF DN

* According to PNEURO P 6602

DS 402 - Pump Speed Curve

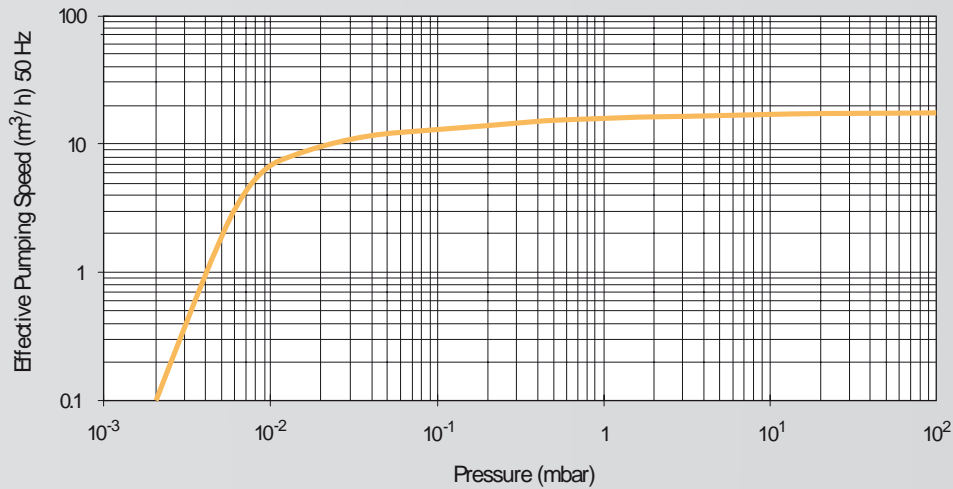

Ordering Information

Dual Stage Rotary Vane Pump	Part Number
DS 402 with 1 phase worldwide motor*	9499330
DS 402 with 3 phase worldwide motor**	9499331
* 1 phase motors (100-120 / 200-230) V ±10% 50/ 60 Hz	
** 3 phase motors (200-220 / 380-415) V ±10% at 50 Hz or (200-230 / 460) V ±10% at 60 Hz	
All motors comply with CE and UL/ CSA standards.	
Minor Maintenance Kit	Part Number
Contains all the valves, O-rings and seals to refurbish the pump to vacuum integrity	9499371
Major Maintenance Kit	Part Number
Includes all the items of the minor kit plus the vanes	9499382

Oil and Accessories	Part Number
Rotary vane fluid, DS19 type, 1 liter	9499390
Rotary vane fluid, DS19 type, 1 liter (USA)*	K7516301
Rotary vane fluid, DS19 type, 1 gallon (USA)	K7516302
Oil mist eliminator	9499395
Oil mist replacement cartridge (pkg. of 2)	9499394
NW 25 oil exhaust filter	9499392
NW 25 oil exhaust replacement cartridge	9499342
Oil return kit	9499376
Oil drain extension	9499375
European plug power cable 2 meters 1 ph	9499396
USA plug power cable 2 meters 1 ph	9499397
UK plug power cable 2 meters 1 ph	9499398
NW 25 centering ring Viton	KC25AV
NW 25 aluminum clamp	KQ25AWP

* When these pumps are used in Leak Detectors applications, we recommend the use of Rotary Vane Fluid (Elite-Z mechanical), P/ N 695409005 as it features a lower vapor pressure.

AGILENT ROTARY VANE PUMP MODELS

▶ Agilent DS 602

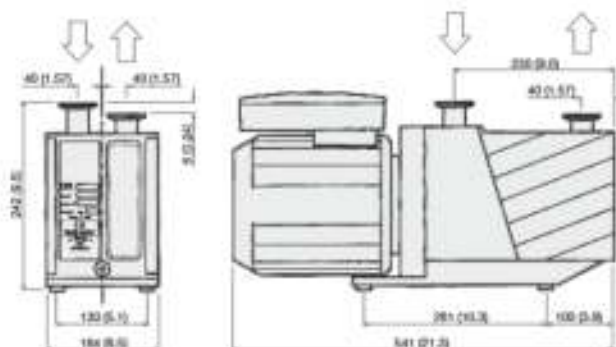

Alternative mounting holes are also available, with thread 1/4-20UNC

Dimensions: millimeters (inches)

Technical Specifications

Free air displacement	60 Hz: 605 l/min (21.4 cfm)	50 Hz: 504 l/min (30.2 m ³ /h)
Pumping speed*	60 Hz: 17.6 cfm	50 Hz: 25 m ³ /h
Ultimate partial pressure*		10 ⁻⁴ mbar
Ultimate total pressure*		2 x 10 ⁻³ mbar
Ultimate total pressure with gas ballast*		1 x 10 ⁻² mbar
Water vapor tolerance		30 mbar
Water vapor capacity		550 g/h
Oil capacity min/max		0.5/1 l
Motor rating 1ph	60 Hz: 0.90 kW	50 Hz: 0.75 kW
Motor rating 3ph	60 Hz: 0.90 kW	50 Hz: 0.75 kW
Nominal rotation speed	60 Hz: 1800 rpm	50 Hz: 1500 rpm
Weight		35 kg (77 lbs)
Inlet flange		25KF DN
Exhaust flange		25KF DN

* According to PNEURO P 6602

DS 602 - Pump Speed Curve

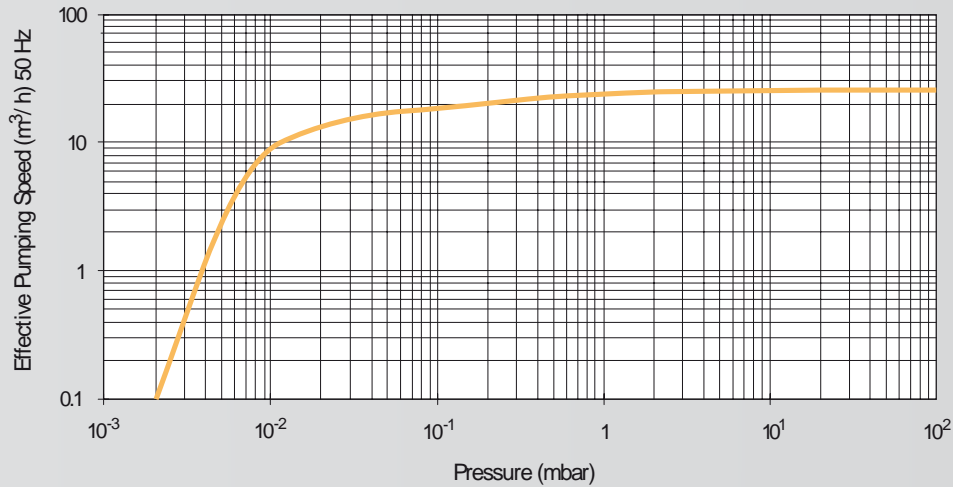

Ordering Information

Dual Stage Rotary Vane Pump	Part Number
DS 602 with 1 phase worldwide motor*	9499335
DS 602 with 3 phase worldwide motor**	9499336
* 1 phase motors (100-120 / 200-230) V ±10%, 50/ 60 Hz	
** 3 phase motors (200-220 / 380-415) V ±10% at 50 Hz or (200-230 / 460) V ±10% at 60 Hz	
All motors comply with CE and UL/ CSA standards.	
Minor Maintenance Kit	Part Number
Contains all the valves, O-rings and seals to refurbish the pump to vacuum integrity	9499371
Major Maintenance Kit	Part Number
Includes all the items of the minor kit plus the vanes	9499382

Oil and Accessories	Part Number
Rotary vane fluid, DS19 type, 1 liter	9499390
Rotary vane fluid, DS19 type, 1 liter (USA)*	K7516301
Rotary vane fluid, DS19 type, 1 gallon (USA)	K7516302
Oil mist eliminator	9499395
Oil mist replacement cartridge (pkg. of 2)	9499394
NW 25 oil exhaust filter	9499392
NW 25 oil exhaust replacement cartridge	9499342
Oil return kit	9499376
Oil drain extension	9499375
European plug power cable 2 meters 1 ph	9499396
USA plug power cable 2 meters 1 ph	9499397
UK plug power cable 2 meters 1 ph	9499398
NW 25 centering ring Viton	KC25AV
NW 25 aluminum clamp	KQ25AWP

* When these pumps are used in Leak Detectors applications, we recommend the use of Rotary Vane Fluid (Elite-Z mechanical), P/ N 695409005 as it features a lower vapor pressure.

AGILENT ROTARY VANE PUMP ACCESSORIES

▶ Exhaust Filters - Oil Mist Eliminator

The exhaust filters (below, left) and the oil mist eliminator (right), retain the oil vapors which would otherwise be expelled into the atmosphere during pumpdown and gas ballast operation.

Some models feature an oil return line to allow condensed oil or fluid to return to the pump reservoir.



Ordering Information

NW25 oil exhaust filter (left)	PN 9499392
Oil mist eliminator DS 102 - DS 602 (right)	PN 9499395

▶ Foreline Roughing Traps

Agilent's new traps are designed to prevent the backstreaming of mechanical pump fluids. Copper and stainless steel gauze inserts are designed to reduce oil backstreaming. Molecular sieve inserts are available for applications where it is desirable to increase water vapor pumping speed while eliminating backstreaming above the trap.



Ordering Information

Foreline/Roughing Traps: please call Agilent for ordering information

For any further details on our rotary vane pump accessories, please contact Agilent Vacuum Products.

Agilent Oil, GP Type Mechanical Pump Fluid

Agilent GP Type Fluid is a mechanical pump fluid recommended for use in non-corrosive applications. As a result of molecular distillation, it has low vapor pressure and, therefore, backstreams less than undistilled refinery products.

Ordering Information

Description	Part Number	Shipping Weight lbs (kg)
1 liter bottle	K7516301	3.5 (1.6)
1 gallon bottle	K7516302	14.0 (6.4)

- Agilent's HS 452 and HS 852 rotary vane pumps employ an innovative frequency inverter technology that delivers optimal and consistent performance throughout the worldwide range of voltage and frequency conditions.
- Operating with low power requirements, the microprocessor-controlled frequency inverter, combined with a 3-phase motor, is an efficient driving unit capable of delivering the high starting torque required for a dual-stage oil pump.
- Green technology: environmentally friendly thanks to reduced power requirements, low start up current, minimum oil mist at pump exhaust.



I/O and RS232/RS485 Communication

- Adjustable pumping speed from 45 to 68 Hz permits easy integration and reduces noise levels.
- Pump performance can be tailored to specific applications to reduce system costs.



Universal Input Voltage

- Truly universal single-phase voltage and frequency provide worldwide compatibility.
- Constant performance at different input frequencies.



Remote Diagnostics

- Remote monitoring and control of oil consumption, power and current.
- Reduces maintenance costs, improves uptime and offers higher reliability.



Reduced Power Requirements

- Inverter technology reduces the power required compared to traditional single phase motors.
- Circuit-breakers are no longer required, resulting in reduced system costs.



Higher Nominal Rotational Speed (2000 rpm)

- The pump is ideally suited for steady and high gas-load applications.

AGILENT ROTARY VANE PUMP MODELS

▶ Agilent HS 452

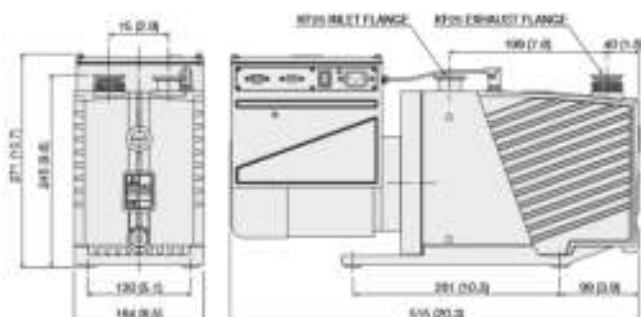

Dimensions: millimeters (inches)

The first rotary vane pumps with truly "smart" capabilities.

- Agilent's HS 452 and HS 652 pumps employ an innovative frequency inverter technology that delivers optimal and consistent performance while encompassing the worldwide range of voltage and frequency conditions.
- Operating with low power requirements, the microprocessor controlled frequency inverter, combined with a 3-phase motor, is an efficient driving unit capable of delivering the high starting torque required of a dual-stage oil pump.
- HS 452 and HS 652 technology solves the common problems inherent in traditional single-phase motors. Smart Pumps start with inrush current about 7 times lower than that of equivalent traditional pumps.
- Unlike traditional pumps, Smart Pump's software driven startup procedure recognizes faulty pumps within seconds, and so avoids uncontrolled load conditions. The result is very easy pump integration.
- The 3-phase inverter output is constant and independent of single-phase input frequencies and voltages. Motor efficiency and power factors remain optimal and as a result motor and pump are easy to drive the pump. Pump performance can be tailored by setting the rotational speed for specific applications. The software monitors and logs pump parameters making it possible to perform pump and system diagnostics.

Technical Specifications

Free air displacement	27 m ³ /h (16 cfm)
Pumping speed*	22 m ³ /h (13 cfm)
Ultimate total pressure*	2 x 10 ⁻³ mbar
Ultimate total pressure with gas ballast*	1 x 10 ⁻² mbar
Operating voltage	100-120/200-240 V ±10%, 50/60 Hz
Inverter maximum output power	780 W
Nominal rotation speed	2000 rpm
Weight	33 kg (73 lbs)

* According to PNEUROD 6602

RoTARy VANE PumPs

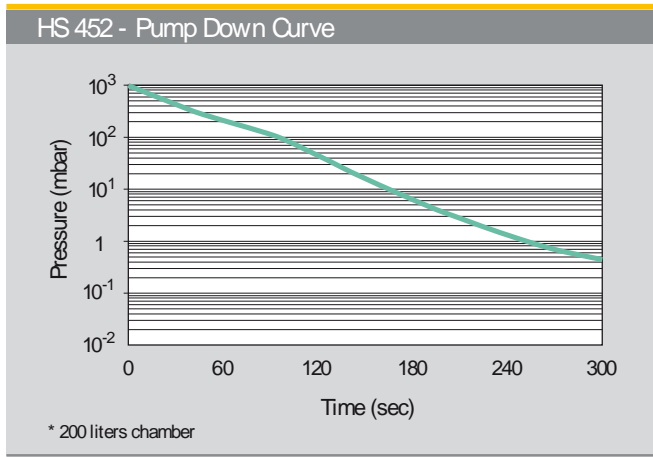
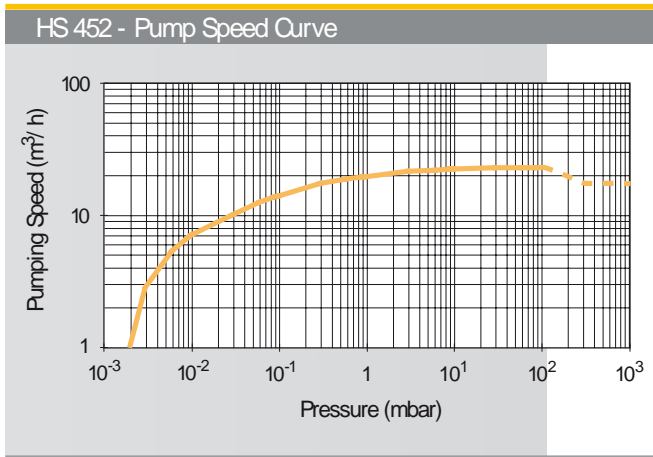

Ordering Information

Pump	Part Number
HS 452 Smart Pump 1 phase worldwide motor	9499360
IP44 accessory connector Kit	9499367

Accessories	Part Number
NW25 oil exhaust filter	9499392
Oil return kit	9499376
Oil drain extension	9499375
Rotary vane fluid, DS19 type, 1 liter	9499390
European plug power cable 2 meters 1 ph	9499396
USA plug power cable 2 meters 1 ph	9499397
UK plug power cable 2 meters 1 ph	9499398
Minor maintenance kit	9499371
Major maintenance kit	9499382

Application Note

Steady state high gas load applications exploit the major benefits of the smart technologies. When operated at pressures lower than the auto-tuning pressure, the HS 452 and HS 652 outperform the equivalent traditional DS 402 and DS 602 pumps by 10% at 60 Hz and by 30% at 50 Hz.

The Smart Pumps can run below auto-tuning pressure at their full speed of 2000 rpm. As shown in the pumping speed curve

at top right, the HS 452 has an auto-tuning pressure of 100 mbar while the HS 652 has an auto-tuning pressure of 40 mbar. Despite the lower power requirements of 780 W max, the Smart Pumps deliver good performance in the roughing phase. Fast cycling or inrush applications need to be evaluated on a case by case basis with our application engineers.

AGILENT ROTARY VANE PUMP MODELS

► Agilent HS 652

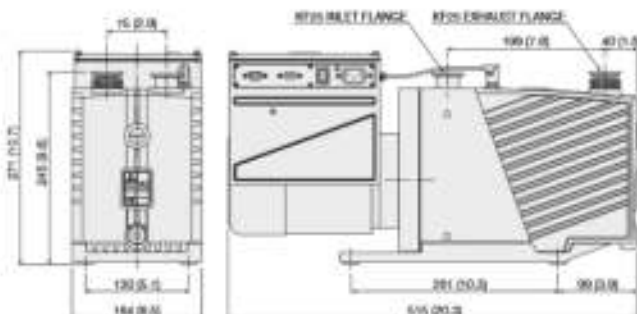

Dimensions: millimeters (inches)

The first rotary vane pumps with truly "smart" capabilities.

- Agilent's HS 452 and HS 652 pumps employ an innovative frequency inverter technology that delivers optimal and consistent performance while encompassing the worldwide range of voltage and frequency conditions.
- Operating with low power requirements, the microprocessor controlled frequency inverter, combined with a 3-phase motor, is an efficient driving unit capable of delivering the high starting torque required of a dual-stage oil pump.
- HS 452 and HS 652 technology solves the common problems inherent in traditional single-phase motors. Smart Pumps start with inrush current about 7 times lower than that of equivalent traditional pumps.
- Unlike traditional pumps, Smart Pump's software driven startup procedure recognizes faulty pumps within seconds, and so avoids uncontrolled load conditions. The result is very easy pump integration.
- The 3-phase inverter output is constant and independent of single-phase input frequencies and voltages. Motor efficiency and power factors remain optimal and as a result motor and pump working temperatures remain low and constant worldwide.
- Smart Pumps can be remotely driven via discrete I/O or RS232/RS485 interfaces. Agilent's T-plus Navigator Software facilitates communication making it very easy to drive the pump. Pump performance can be tailored by setting the rotational speed for specific applications. The software monitors and logs pump parameters making it possible to perform pump and system diagnostics.

Technical Specifications

Free air displacement	40.3 m ³ /h (23.8 cfm)
Pumping speed*	32 m ³ /h (19 cfm)
Ultimate total pressure*	2 x 10 ⁻³ mbar
Ultimate total pressure with gas ballast*	1 x 10 ⁻² mbar
Operating voltage	100-120/200-240 V ±10%, 50/60 Hz
Inverter maximum output power	780 W
Nominal rotation speed	2000 rpm
Weight	33 kg (73 lbs)

* According to PNEURDP 6602

RoTARy VANE PumPs

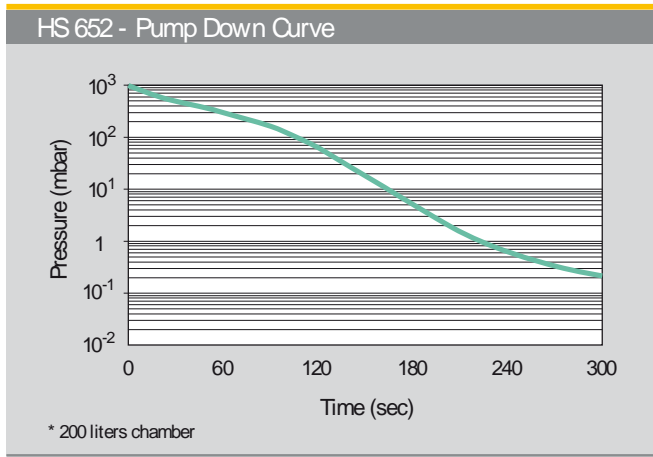
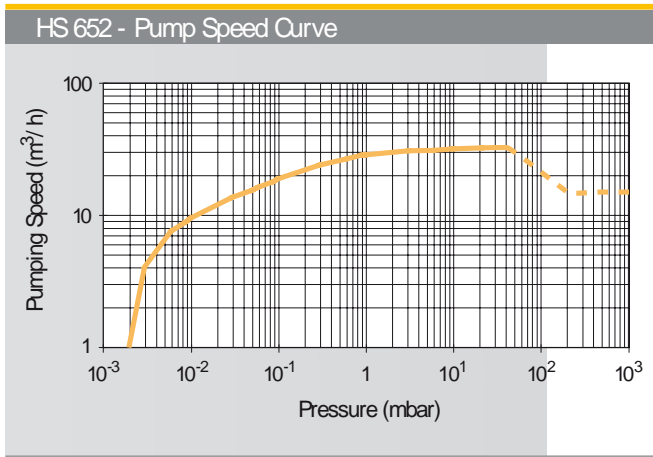

Ordering Information

Pump	Part Number
HS 652 Smart Pump 1 phase worldwide motor	9499365
IP44 accessory connector Kit	9499367

Accessories	Part Number
NW25 oil exhaust filter	9499392
Oil return kit	9499376
Oil drain extension	9499375
Rotary vane fluid, DS19 type, 1 liter	9499390
European plug power cable 2 meters 1 ph	9499396
USA plug power cable 2 meters 1 ph	9499397
UK plug power cable 2 meters 1 ph	9499398
Minor maintenance kit	9499371
Major maintenance kit	9499382

Application Note

Steady state high gas load applications exploit the major benefits of the smart technologies. When operated at pressures lower than the auto-tuning pressure, the HS 452 and HS 652 outperform the equivalent traditional DS402 and DS602 pumps by 10% at 60 Hz and by 30% at 50 Hz. The Smart Pumps can run below auto-tuning pressure at their full speed of 2000 rpm. As shown in the pumping speed curve

at top right, the HS 452 has an auto-tuning pressure of 100 mbar while the HS 652 has an auto-tuning pressure of 40 mbar. Despite the lower power requirements of 780 W max, the Smart Pumps deliver good performance in the roughing phase. Fast cycling or inrush applications need to be evaluated on a case by case basis with our application engineers.

MS 40+ FEATURES AND BENEFITS

Mono Stage Rotary Vane Pump Small Footprint, High Pumping Capacity

- Sophisticated Electronics and excellent mechanical design allow high pumping capacity and reduced dimensions.
- Suitable for steady and high gas throughput conditions at pressures below 10 Torr, in applications like Mass Spectrometry (including LC-MS, ICP-MS, GC-TOF-MS, etc.), Electron Microscopy, and other Scientific Instrumentation.

Please contact Agilent to qualify use in cyclic applications.



Interface Capabilities

- I/O and RS232/RS485 enable adjustment of operating parameters simplifying system integration
- Remote diagnostic allow the control of:
 - Oil level
 - Temperature
 - Power
 - Current



T-Plus Software

- T-Plus software allows control of pump parameters via PC, improving uptime and reliability, and reducing maintenance costs



Worldwide Service Capability

- Three levels of Product Support
 - 24h Advance Exchange
 - Factory Repair
 - Upgrade Programallow global coverage of service needs to maximize productivity and uptime

ROTARY VANE PUMPS



Inverter Technology

- Proven on-board electronics allows constant performance worldwide
- Truly universal voltage and frequency
- Single phase
- Inverter electronics enable tailoring pumping speed to each application



Highest Performances / Size Ratio

- Base pressure below 5×10^{-2} mbar (3.75×10^{-2} Torr)
- High pumping speed over a wide range, from atmosphere to 1 mbar (0.75 Torr)
- Inverter technology allows to manage pumping speed to more than $45 \text{ m}^3/\text{h}$ (26.5 cfm)
- Best noise level, with the highest throughput



Smallest Dimensions

- The smallest single stage $40 \text{ m}^3/\text{h}$ pump in the market. $297 \times 418 \times 225 \text{ mm}$ (11.69 x 16.46 x 8.86 inches)
- Including on-board electronics, anti suck-back valve, integrated exhaust filter and oil return kit
- Easier system integration
- Simple maintenance
- Allows smaller overall instrument design, therefore reducing costs



Green Technology

- Environmentally friendly and cost-effective due to reduced power requirements, low start up current ($< 10 \text{ A}$) and stand by mode

AGILENT ROTARY VANE PUMP MODELS

▶ Agilent MS 40+

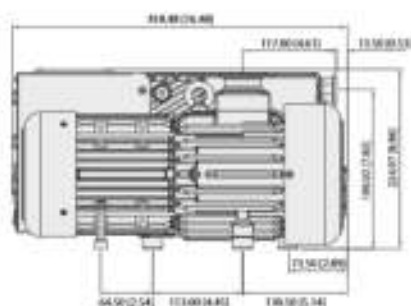
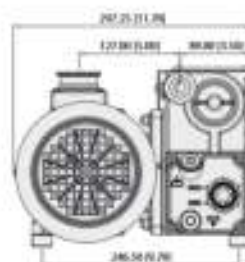

Dimensions: millimeters (inches)

Technical Specifications

	9499225	9499240	9499241
Free air displacement	828 l/min (29.2 cfm; 49.7 m ³ /h)	828 l/min (29.2 cfm; 49.7 m ³ /h)	828 l/min (29.2 cfm; 49.7 m ³ /h)
Pumping speed (at 5 mbar inlet pressure)	40 m ³ /h	40 m ³ /h	40 m ³ /h
Ultimate total pressure*	5x10 ⁻² mbar	5x10 ⁻² mbar	5x10 ⁻² mbar
Oil capacity min/max	1 l	1 l	1 l
Motor rating 1ph	0.75 kW	0.75 kW	0.75 kW
Noise level with gas ballast closed	≤ 62 dB(A)	≤ 62 dB(A)	≤ 62 dB(A)
Oil temperature (pump operating)	60 °C 140 °F	60 °C 140 °F	60 °C 140 °F
IP Value		20	
Installation category		II	
Pollution degree		2	
Operating temperature range	12-40 °C	12-40 °C	12-40 °C
Nominal rotation speed	1450 rpm	1450 rpm	1450 rpm
Weight	33 kg (73 lbs)	33 kg (73 lbs)	33 kg (73 lbs)
Inlet flange	25KF DN	40KF DN	40KF DN
Exhaust flange	25KF DN	25KF DN	25KF DN
Dimensions:			
- length	418 mm	418 mm	418 mm
- width	297 mm	297 mm	297 mm
- height	228 mm	228 mm	228 mm
Nominal Input Voltage	200-240 V	200-240 V	200-240 V
Input frequency	50/60 Hz	50/60 Hz	50/60 Hz
Max input power	1200 VA	1200 VA	1200 VA
Internal Main Fuse (TT type)	12.5 A	12.5 A	12.5 A

* According to PNEURO P 6602 - No gas ballast port

RoTARy VANE PumPs

MS 40+ Pump Speed Curve

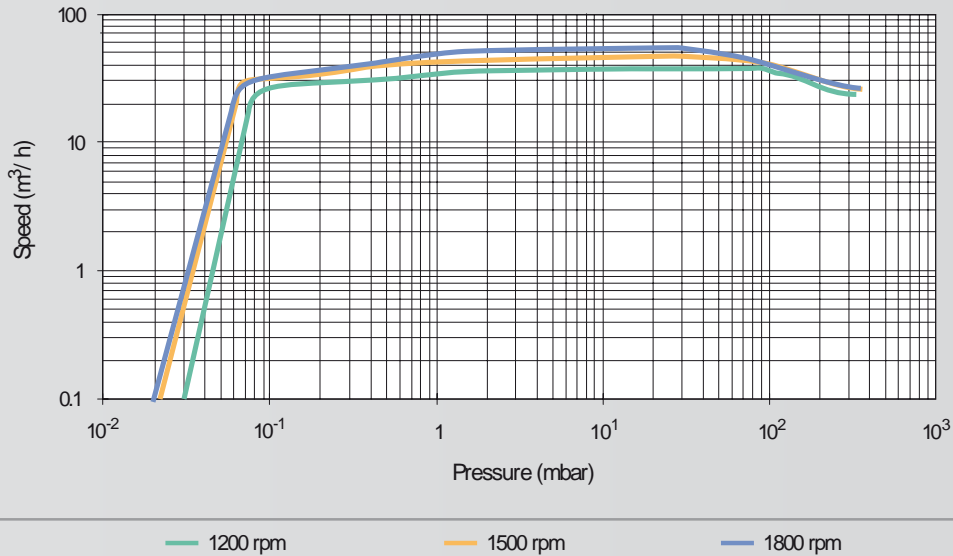

Ordering Information

Dual Stage Rotary Vane Pump	Part Number
MS 40+ RVP, 25KF Inlet Flange, with I/O and RS232/ 485 Interface, without Oil Level Sensor	9499225
MS 40+ RVP, 40KF Inlet Flange, Full Optional with I/O and RS232/ 485 Interface, with Oil Level Sensor	9499240
MS 40+ RVP, 40KF Inlet Flange, Base Version	9499241

Oil and Accessories	Part Number
MS 40+ Exhaust filter	9499201
MS 40+ 1 Litre Oil Tank	9499202
MS 40+ Maintenance Kit	9499203
Power cable EU	9499396
208Vac US Power cable	9499400
Power cable UK	9499398
Power cable IEC320	9499399
T-PLUS Navigator SW (w/ serial cable)	9699883